

Enhanced Precision Super Duty Casters

...Featuring New HPI™ Swivel Technology

★ = same day/next day PRONTO® shipment.

EPSP Selection Table

3YR = 3 Year Warranty applies

Dia. A	Wheel			Swivel Caster		Rigid Caster		Load Cap. Lbs.	Total Hght. B	Swivel Offset G
	Face	Type	Replacement Number	Hamilton No. Tapered / Prec. BB	Wt. Lbs.	Hamilton No. Tapered / Prec. BB.	Wt. Lbs.			
6	3	Duralast®	W-630-DB-1	S-EPSP-63DB	3YR 36	R-EPSP-63DB	3YR 29	2200	8½	2½
		Duralast® XC	W-630-DB70-1	S-EPSP-63DB70	3YR 36	R-EPSP-63DB70	3YR 28	2860		
		Forged Steel	W-630-FST-1¼	★S-EPSP-63FST	3YR 45	★R-EPSP-63FST	3YR 37	10,000		
		Nylast™‡	W-630-NYB-1	S-EPSP-63NYB	3YR 33	R-EPSP-63NYB	3YR 25	6000		
		Ultralast™	W-630-TRB-1	S-EPSP-63TRB	3YR 36	R-EPSP-63TRB	3YR 29	2600		
8	3	Duralast®	W-830-DB-1	S-EPSP-83DB	3YR 44	R-EPSP-83DB	3YR 36	2500	10½	2½
		Duralast® XC	W-830-DB70-1	S-EPSP-83DB70	3YR 44	R-EPSP-83DB70	3YR 36	3250		
		Forged Steel	W-830-FST-1¼	★S-EPSP-83FST	3YR 48	★R-EPSP-83FST	3YR 40	10,000		
		Nylast™‡	W-830-NYB-1	S-EPSP-83NYB	3YR 34	R-EPSP-83NYB	3YR 26	6500		
		Superlast®	W-830-SYT-1¼	★S-EPSP-83SYT	3YR 51	★R-EPSP-83SYT	3YR 43	3500		
		Superlast®XC	W-830-SYT70-1¼	S-EPSP-83SYT70	3YR 51	R-EPSP-83SYT70	3YR 43	4550		
	4	Super Ultralast™	W-830-STRB-1	S-EPSP-83STRB	3YR 51	R-EPSP-83STRB	3YR 43	4200		
		Ultralast™	W-830-TRB-1	S-EPSP-83TRB	3YR 44	R-EPSP-83TRB	3YR 36	3000		
		Duralast®	W-840-DT-1¼	S-EPSP-84DT	3YR 46	R-EPSP-84DT	3YR 38	3200		
		Forged Steel	W-840-FST-1¼	S-EPSP-84FST	3YR 64	R-EPSP-84FST	3YR 56	10,000		
10	3	Duralast®	W-1030-DT-1¼	S-EPSP-13DT	3YR 54	R-EPSP-13DT	3YR 46	3000	12½	2½
		Duralast® XC	W-1030-DT70-1¼	S-EPSP-13DT70	3YR 54	R-EPSP-13DT70	3YR 46	3900		
		Forged Steel	W-1030-FST-1¼	S-EPSP-13FST	3YR 59	R-EPSP-13FST	3YR 51	6500		
		Ultralast™	W-1030-TRT-1¼	S-EPSP-13TRT	3YR 54	R-EPSP-13TRT	3YR 46	3600		
	4	Forged Steel	W-1040-FST-1¼	★S-EPSP-104FST	3YR 80	★R-EPSP-104FST	3YR 72	10,000		
		Superlast®	W-1040-SYT-1¼	★S-EPSP-104SYT	3YR 74	★R-EPSP-104SYT	3YR 66	5000		
		Superlast®XC	W-1040-SYT70-1¼	S-EPSP-104SYT70	3YR 74	R-EPSP-104SYT70	3YR 66	6500		
		Super Ultralast™	W-1040-STRT-1¼	S-EPSP-104STRT	3YR 74	R-EPSP-104STRT	3YR 66	6000		
12	4	Forged Steel	W-1240-FST-1¼	S-EPSP-124FST	3YR 156	R-EPSP-124FST	3YR 149	10,000		
		Superlast®	W-1240-SYT-T-1¼	S-EPSP-124SYT	3YR 92	R-EPSP-124SYT	3YR 85	6000		
		Superlast®XC	W-1240-SYT70-1¼	S-EPSP-124SYT70	3YR 92	R-EPSP-124SYT70	3YR 85	7800		
		Super Ultralast™	W-1240-STRT-1¼	S-EPSP-124STRT	3YR 92	R-EPSP-124STRT	3YR 85	7200		

‡ Straight-sided wheel.

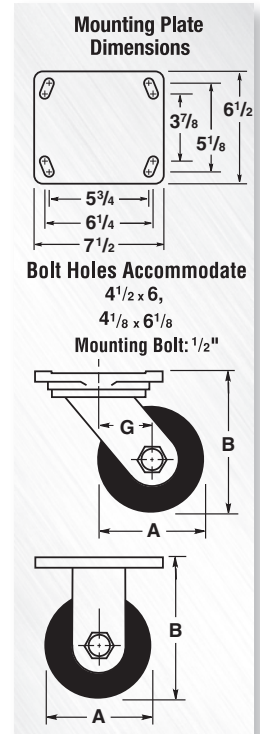

Mini-Mite™ Caster

QUALITY FEATURES

Swivel Construction – Kingpinless-design 7¼" outside diameter outer ring base with CNC-machined 6" diameter hardened raceway and polished steel balls.

Axle – 1" diameter grade 5 lube axle.

Wheel Bearings – (2) 1" needle thrust bearings and (2) 1" needle roller bearings.

Lubrication Fitting – Ball-check type in swivel assembly.

Hamilton is proud to introduce the new Mini-Mite caster for those applications that demand an extremely low overall height and an incredibly high capacity. Each Mini-Mite caster stands only 6" tall and supports up to 10,000 lbs. Hamilton engineers accomplished this feat using kingpinless swivel construction with an immense 6" diameter raceway. The raceways are CNC-machined and hardened to handle the extra capacity. The caster wheel is a 4" x 3" wide 1045 steel roller and inside are four bearings: (2) needle thrust and (2) needle roller. The outside diameter of the ring is 7¼" and there are four ½-13 holes for mounting 3" x 3" wide. The rig and wheel are painted battleship gray enamel.

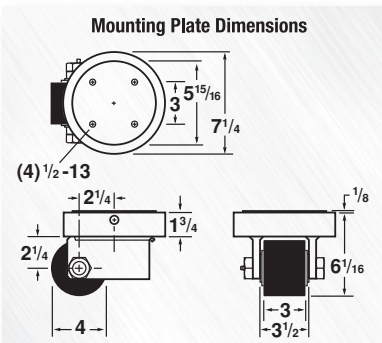

MM Selection Table

Dia. A	Wheel		Swivel Caster		Load Cap. Lbs.	Swivel Radius	
	Face	Type	Replacement Number	Hamilton Model No.			Wt. Lbs.
4	3	Forged Steel	W-430-FSX-1	S-MM-43FS	37	10,000	2½