

Medium Service Casters



#S-MS-6NF
Swivel showing
Poly-Tech® wheel

Medium Service Series Casters, differentiated by the 5" x 5½" top plate, are proven performers in Hamilton's 900 lbs. class offering. These rugged, yet economical casters accommodate a wide selection of 2" face wheels.

Four brake options are available and three are available *Pronto*® – Hamilton's free shipping service for same day or next day shipment.

QUALITY FEATURES

Swivel Construction – cold forged steel mounting plate and horn base. Legs ¼" plate steel, formed for increased strength and continuously welded to horn base.

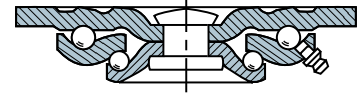

Kingpin – permanent rivet type, ⅝" diameter heat treated steel.

Main and Secondary Load Bearings – hardened and polished steel balls rotate in two smoothly coined, case hardened raceways.

Axle – ½" diameter bolt with lock nut.

Lubrication Fittings – in swivel assembly and to roller bearings in most wheels.

OPTIONAL ACCESSORIES

more help on page 13

- Sealed Swivel Assembly (★-SS)
- Wheel Bearing Seals (-BS)
- Thread Guards, for most models.



FEATURED WHEEL BEARINGS



Precision Ball Bearings (B)



Straight Roller Bearings (L)

BRAKE CHOICES for more help, see page 20

★-CB



Tread Contact Brake

★-FB



Side Foot Brake

★-FRB



Rap-A-Round Foot Brake

-B



Thumbscrew Brake

WHEEL CHOICES for more help, see pages 14 & 15



Duralast®



Metal



Plastex



Polylast™



Poly-Soft®



Poly-Tech®



M.O. Rubber



Unilast®



Versa-Tech®

★ = same day/next day *PRONTO*® shipment.

MS Series Selection Table

Dia. A	Wheel			Swivel Caster		Rigid Caster		Load Cap. Lbs.	Overall Height B	Swivel Offset G
	Face	Type	Replacement Number	Hamilton Model No.	Wt. Lbs.	Hamilton Model No.	Wt. Lbs.			
5	2	Duralast®	W-520-DB-½	★ S-MS-5DB	9	★ R-MS-5DB	8	900	6½	1%
		Metal	W-520-MB-½	★ S-MS-5MB	10	★ R-MS-5MB	9	900		
		Plastex	W-520-P-¾	★ S-MS-5P	7	★ R-MS-5P	6	900		
		Poly-Soft®	W-520-SPB-½	★ S-MS-5SPB	9	★ R-MS-5SPB	8	840		
		Poly-Tech®*	W-520-NF-¾	★ S-MS-5NF	7	★ R-MS-5NF	5	900		
		M.O. Rubber	W-520-R-¾	★ S-MS-5R	9	★ R-MS-5R	7	350		
		Unilast™	W-520-UYB-½	★ S-MS-5UYB	7	★ R-MS-5UYB	6	900		
		Versa-Tech®*	W-520-TE-¾	★ S-MS-5TE	6	★ R-MS-5TE	5	350		
6	2	Duralast®	W-620-DB-½	★ S-MS-6DB	11	★ R-MS-6DB	10	900	7½	1¼
		Metal	W-620-MB-½	★ S-MS-6MB	11	★ R-MS-6MB	10	900		
		Plastex	W-620-P-¾	★ S-MS-6P	8	★ R-MS-6P	7	900		
		Polylast™	W-622-AYB-½	★ S-MS-62AYB	9	★ R-MS-62AYB	8	600		
		Poly-Soft®	W-620-SPB-½	★ S-MS-6SPB	11	★ R-MS-6SPB	10	900		
		Poly-Tech®*	W-620-NF-¾	★ S-MS-6NF	7	★ R-MS-6NF	6	900		
		M.O. Rubber	W-620-R-¾	★ S-MS-6R	10	★ R-MS-6R	9	410		
		Unilast™	W-620-UYB-½	★ S-MS-6UYB	7	★ R-MS-6UYB	6	900		
Versa-Tech®*	W-620-TE-¾	★ S-MS-6TE	7	★ R-MS-6TE	6	410				
8	2	Duralast®	W-820-DB-½	★ S-MS-8DB	14	★ R-MS-8DB	13	900	9½	2%
		Metal	W-820-MB-½	★ S-MS-8MB	13	★ R-MS-8MB	12	900		
		Plastex	W-820-P-¾	★ S-MS-8P	9	★ R-MS-8P	8	900		
		Polylast™	W-822-AYB-½	★ S-MS-82AYB	12	★ R-MS-82AYB	11	900		
		Poly-Soft®	W-820-SPB-½	★ S-MS-8SPB	14	★ R-MS-8SPB	13	900		
		Poly-Tech®*	W-820-NF-¾	★ S-MS-8NF	8	★ R-MS-8NF	8	900		
		M.O. Rubber	W-820-R-¾	★ S-MS-8R	13	★ R-MS-8R	12	500		
		Unilast™	W-820-UYB-½	★ S-MS-8UYB	8	★ R-MS-8UYB	7	900		
Versa-Tech®*	W-820-TE-¾	★ S-MS-8TE	8	★ R-MS-8TE	7	500				

* These wheels lubricated through lube axle.

