

## Cush-N-Aire Casters

### QUALITY FEATURES

**Swivel Construction** – drop forged steel mounting plate and horn base. Legs ¼" thick on 8", 10", & 12" (7112 only) models; ⅜" on 12", 16", 21" and 25"; and ½" on 18" models, welded inside and outside.

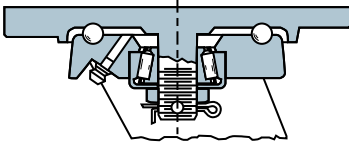

**Kingpin** – integrally forged with mounting plate, ¾" diameter on 8", 10" & 12" (7112 only) models; 1" diameter on 12"-18" models; and 1¼" dia. on 21" and 25" models.

**Main Load Bearing** – large diameter raceway machined for hardened and polished steel balls.

**Secondary Load Bearing** – precision tapered roller bearing capped with grease retainer.

**Axle** – bolt and nut type: ½" diameter on 8" and 10" roller bearing models; ¾" diameter on 10" tapered bearing models and all 12" models; 1" diameter on all 16" and 18" models; 1¼" on 21" and 25" models.

**Tires** – 8", 10", 12" and #7116 are 4-ply rated; #71166 is 6-ply rated; #71188 is 8-ply rated; 21" and 25" models are 10-ply rated.

The new 7100 Series of pneumatic casters combines the proven heavy-duty forged steel construction of the 7000 Series with the industry's most popular top plate – 4" x 5". The 7100 Series Casters are also enhanced with a bright zinc plate finish to prevent rust and wear in indoor and outdoor applications.

Because pneumatic-tired casters cushion loads and roll well on paved or concrete surfaces, this series is well-suited for aerospace ground support equipment (power towed and manual operations), and sensitive cargo such as military weaponry and any other miscellaneous equipment requiring extra care during transport.



#S-7111-PR Swivel



### OPTIONAL ACCESSORIES *more help on page 13*



- **Swivel Locks** – 4 position (-4SL)  
–convert swivel to rigid for straight line steering
- **Special Overall Height**
- **Foam Filled Wheels**
- **Gray Non-marking Tires**



★ = same day/next day PRONTO® shipment.

### Mounting Plate Dimensions

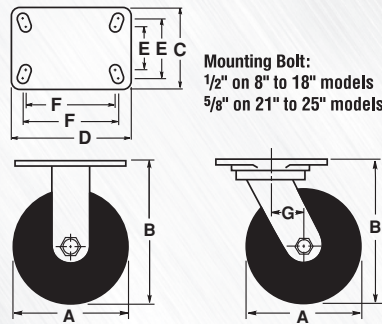

### BRAKE CHOICES *for more help, see page 20*

-FCB

★-FB

★-FRB

-ZB

-B, -HB



Foot Contact Brake  
[8" to 18" models]



Side Foot Brake  
[8" to 12" models]



Rap-A-Round  
Foot Brake  
[8" to 12" models]



Heavy Duty  
Contact Brake  
[8" & 10" models]



Thumbscrew Brake  
[8" to 12" models,  
-HB on 16" & 18"]

### 7100 Series Selection Table

3YR = 3 Year Warranty applies

Nom. Dia. A	Wheel				Swivel Caster		Rigid Caster		Load Cap. Lbs.	Overall Height B♦	Swivel Offset G	Mounting Plate	
	Tire Size	Replacement Number	Max. Air	Bearing Type	Hamilton Model No.	Wt. Lbs.	Hamilton Model No.	Wt. Lbs.				Size C&D	Holes E&F
8	2.80/2.50-4	W-8-PR-¾	50	Roller	★S-7108-PR	12	★R-7108-PR	8	330	10%	2¼	4 x 5*	3 x 3¾ slotted to 2½ x 3
	2.80/2.50-4	W-8-PR-¾	50	Roller	S-7118-PR	12	R-7118-PR	9	330	10%	2¼	4½ x 6½	3¾ x 5¼ slotted to 2½ x 4½
10	3.40/3.00-5	W-10-PR-¾	100	Roller	★S-7110-PR	14	★R-7110-PR	10	480	12½	3	4 x 5*	3 x 3¾ slotted to 2½ x 3
	3.40/3.00-5	W-10-PR-¾	100	Roller	S-7111-PR	14	R-7111-PR	11	480	12½	3	4½ x 6½	3¾ x 5¼ slotted to 2½ x 4½
	3.40/3.00-5	W-10-PRT-¾	100	Tapered	S-71104-PR 3YR	14	R-71104-PR 3YR	11	480	12½	3		
12	4.10/3.50-6	W-12-PR-1	50	Roller	★S-7112-PR	17	★R-7112-PR	14	625	15¼	3%	4 x 5*	3 x 3¾ slotted to 2½ x 3
	4.10/3.50-6	W-12-PR-1	50	Roller	S-7113-PR	31	R-7113-PR	24	625	15½	3½	6½ x 7½ (swivel)	4¾ x 6¾
	4.10/3.50-6	W-12-PRT-¾	50	Tapered	S-71124-PR 3YR	31	R-71124-PR 3YR	24	625	15½	3½		
16	4.80-8	W-164-PR-1	60	Roller	S-7116-PR	36	R-7116-PR	29	960	18¾	4½	5½ x 7½ (rigid)	4¾ x 6¾
	4.80-8	W-166-PRT-1	90	Tapered	S-71166-PR 3YR	39	R-71166-PR 3YR	32	1220	18¾	4½		
18	5.70-8	W-188-PRT-1	115	Tapered	S-71188-PR 3YR	50	R-71188-PR 3YR	44	1655	21¼	5	8½ x 8½	7 x 7
21	6.90-9	W-210-PRT-1¼	125	Tapered	S-71210-PR 3YR	90	R-71210-PR 3YR	73	2500	24½	5		
25	7.50-10	W-250-PRT-1¼	100	Tapered	S-71250-PR 3YR	112	R-71250-PR 3YR	95	3700	28¾	5		

♦ Approximate since O.D. of tires can vary, as will deflection with pressure and loading.

\* Rigid top plate is 4" x 4½"; Holes are 2¾" x 3¾" slotted to 3" x 3".