

Whirlaway Casters

Series WW — Cap. to 550 lbs.

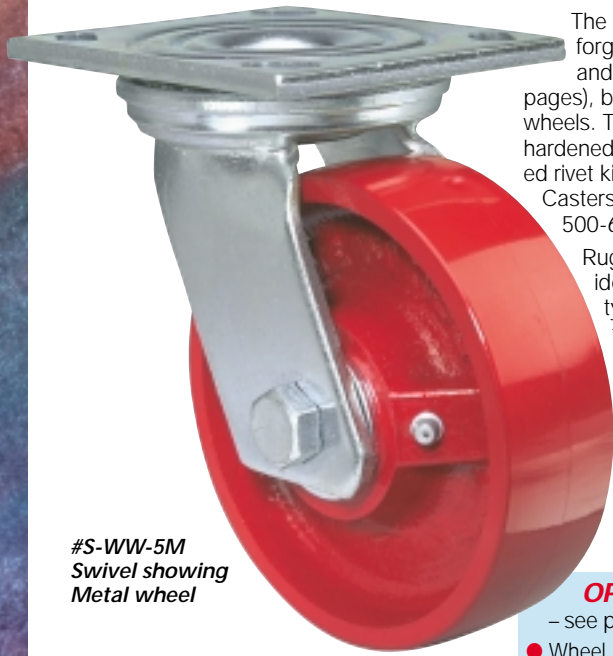

#S-WW-5M
Swivel showing
Metal wheel

The **Whirlaway** Series is the cold forged companion to the **MS**, **GS**, and **52** Series (covered in earlier pages), but scaled down for 1½" wide wheels. The two separate coined and case hardened raceways, joined by a heat treated rivet kingpin, make **Whirlaway** Swivel Casters top performers and sellers in the 500-600 lb. duty class.

Rugged ¼" thick mounting plates are ideal for distortion-free welding to all types of mobile equipment, or bolt them on through slotted holes that fit two popular template patterns. All **Series WW** casters sport bright zinc plated finish.

QUALITY FEATURES:

Swivel Construction – cold forged steel mounting plate and horn base. Legs ¼" plate steel, contoured to increase strength and welding area to the horn base.

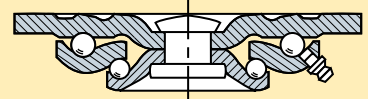

Kingpin – ⅝" dia. orbitally formed rivet.

Main and Secondary Load Bearings – hardened and polished steel balls rotate in two heat treated raceways.

Axle – ½" diameter bolt with lock nut.

Wheel Bearings – ⅝" case hardened straight roller bearing rotates on ⅝" O.D. x ½" I.D. hardened and ground steel spanner bushing. (Exception: ⅝" flanged Delrin® bearings standard in **Aqualite**® Wheels, roller bearings optional; and ball bearings standard in 8"x 1½" **Vulcalite** Wheel.)

Ball Check Lubrication Fittings – in swivel assembly and to roller bearings in most wheels.

OPTIONAL ACCESSORIES

– see pages 18 & 19.

- Wheel Brakes (★-FB).
- Wheel Bearing Seals.
- ★ Sealed Swivel Assembly.
- Delrin® Bearings, for most wheels—see page 11.
- Thread guards, for most models.

#S-WW-5R-FB



All swivel and rigid models on this page except 8" are available with this cam operated foot brake (to order, suffix -FB to catalog number).

Wheel Types



★ = available for 1-2 day **PRONTO**® shipment.

Dimensions in Inches

Dia. A	Wheel			Swivel Caster		Rigid Caster		Load Cap. Lbs.	Overall Height B	Swivel Offset G
	Face	Type	Replacement Number	Catalog Number	Wt. Lbs.	Catalog Number	Wt. Lbs.			
3 ¼	1 ½	Duralast**	W-315-D-⅝	★S-WW-3D	6	★R-WW-3D	5	475	5 ¼	1 ½
		Plastex*	W-315-P-⅝	★S-WW-3P	5 ½	★R-WW-3P	4 ½	550		
4	1 ½	Aqualite®	W-415-AZ-⅝	★S-WW-4AZ	4	★R-WW-4AZ	3 ¼	400	5%	1 ½
		Duralast**	W-415-D-⅝	★S-WW-4D	6	★R-WW-4D	5 ¼	550		
		Ebonite*	W-415-EH-⅝	★S-WW-4E	4 ½	★R-WW-4E	3 ¾	300		
		Flexonite*	W-415-FH-⅝	★S-WW-4F	4 ½	★R-WW-4F	3 ¾	200		
		Metal	W-415-M-⅝	★S-WW-4M	6 ¼	★R-WW-4M	5 ½	550		
		Plastex*	W-415-P-⅝	★S-WW-4P	4 ½	★R-WW-4P	3 ¾	550		
		M.O. Rubber*	W-415-R-⅝	★S-WW-4R	6	★R-WW-4R	3 ¼	200		
		Aqualite®	W-515-AZ-⅝	★S-WW-5AZ	4 ½	★R-WW-5AZ	5	450		
5	1 ½	Duralast®	W-515-D-⅝	★S-WW-5D	6 ½	★R-WW-5D	5 ¾	550	6%	1 ½
		Ebonite*	W-515-EH-⅝	★S-WW-5E	5 ¼	★R-WW-5E	4 ½	450		
		Flexonite*	W-515-FH-⅝	★S-WW-5F	5 ¼	★R-WW-5F	4 ½	240		
		Metal	W-515-M-⅝	★S-WW-5M	7	★R-WW-5M	6 ¼	550		
		Plastex	W-515-P-⅝	★S-WW-5P	5	★R-WW-5P	4 ¼	550		
		M.O. Rubber	W-515-R-⅝	★S-WW-5R	6 ½	★R-WW-5R	5 ¾	240		
6	1 ½	Aqualite®	W-615-AZ-⅝	★S-WW-6AZ	5 ¼	★R-WW-6AZ	4 ¼	550	7 ½	1 ⅞
		Duralast®	W-615-D-⅝	★S-WW-6D	8 ¼	★R-WW-6D	7 ¼	550		
		Flexonite*	W-615-FH-⅝	★S-WW-6F	6	★R-WW-6F	5	280		
		Metal	W-615-M-⅝	★S-WW-6M	7 ¼	★R-WW-6M	6 ¼	550		
		Plastex	W-615-P-⅝	★S-WW-6P	6	★R-WW-6P	5	550		
8	1 ½	M.O. Rubber	W-615-R-⅝	★S-WW-6R	7 ½	★R-WW-6R	6 ½	280	9 ½	2 ¾
		Vulcalite™	W-815-AR-⅝	★S-WW-8AR	7 ½	★R-WW-8AR	7	375		

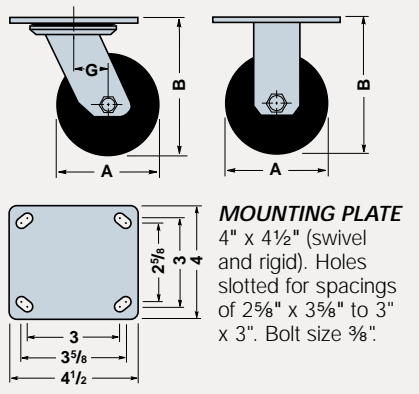

*These wheels lubricated through lube axle.